



Helping to keep the lights on,
businesses running
and communities strong®

GIC Blocker Update

Michael J. Londo, American Transmission Co.
September 12, 2019

Geomagnetically Induced Current

From PJM Report

Ground induced current example:

- In this standard transmission line setup GICs flow from the earth into the grounded neutral of a three phase wye connected transformer, where it divides evenly in each phase of the transformer. The GIC then proceeds into transmission lines and flows to other transformers, returning from them to earth.

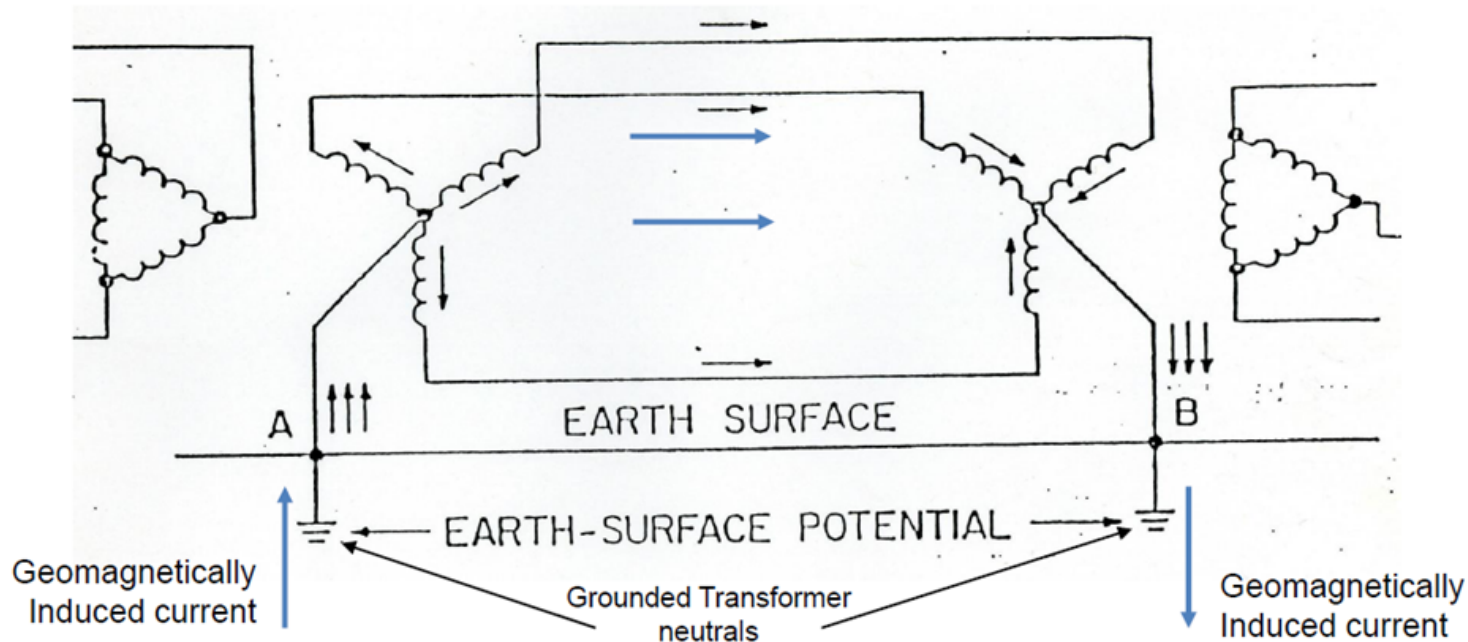



ABB





ATC and EMPrimus R&D

Changes to the GIC Blocker

- **Fail Safe Resilience**
 - Spark Gap
 - Non consumable
 - Repeatable
 - Inspected after 10 events
- **Operational Enhancements**
 - Rogowski Coil (N-G path proof)
 - DC Voltage Probe (automation)
 - Breaker status (SCADA)
 - Spark gap counter (maintenance)
 - Kirk Key Interlock for bypass

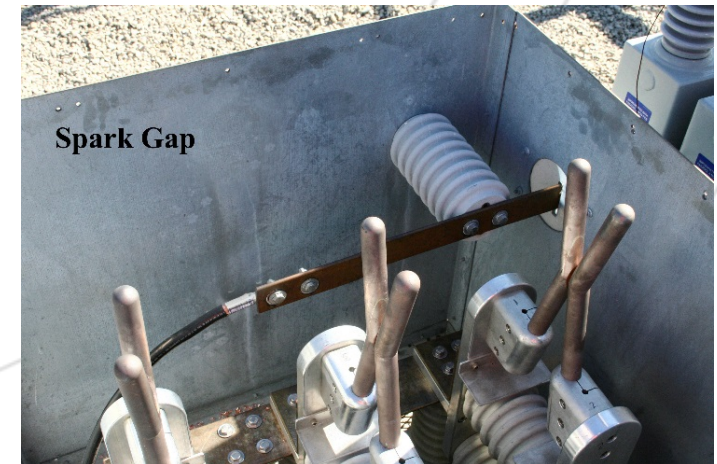

ATC's Plan Model—GIC and Geology

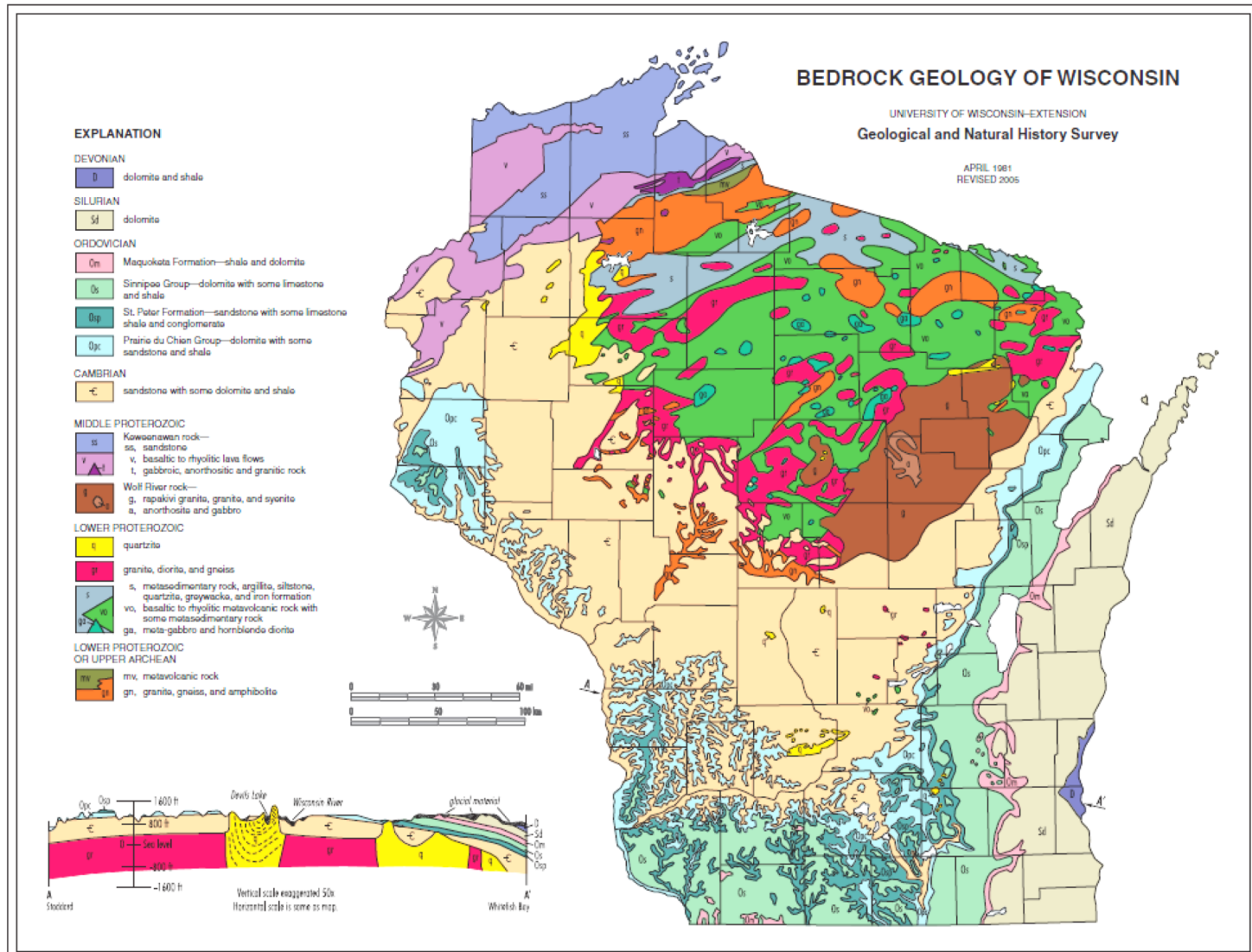

BEDROCK GEOLOGY OF WISCONSIN

UNIVERSITY OF WISCONSIN
 Geological and Natural History Survey
 PROJECT
 REVISED

EXPLANATION

DEVONIAN

D dolomite and shale

SILURIAN

Sd dolomite

ORDOVICIAN

Om Maquoketa Formation—shale and dolomite

Os Sinopec Group—dolomite with some limestone and shale

Osp St. Peter Formation—sandstone with some limestone shale and conglomerate

Opc Prairie du Chien Group—dolomite with some sandstone and shale

CAMBRIAN

c sandstone with some dolomite and shale

MIDDLE PROTEROZOIC

ss Keweenaw rock—
 ss, sandstone
 v, basaltic to rhyolitic lava flows
 t, gabbroic, anorthositic and granitic rock

Wolf River rock—
 g, rapakivi granite, granite, and syenite
 a, anorthositic and gabbro

LOWER PROTEROZOIC

q quartzite

g granite, diorite, and gneiss

s, metasedimentary rock, argillite, siltstone, quartzite, graywacke, and iron formation
 vo, basaltic to rhyolitic metavolcanic rock with some metasedimentary rock
 ga, meta-gabbro and hornblende diorite

LOWER PROTEROZOIC OR UPPER ARCHEAN

mv, metavolcanic rock

gn, granite, gneiss, and amphibolite

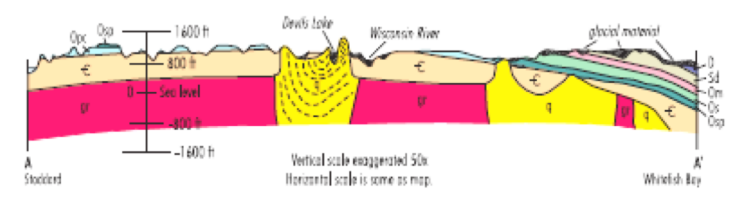
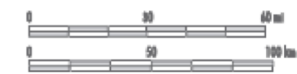
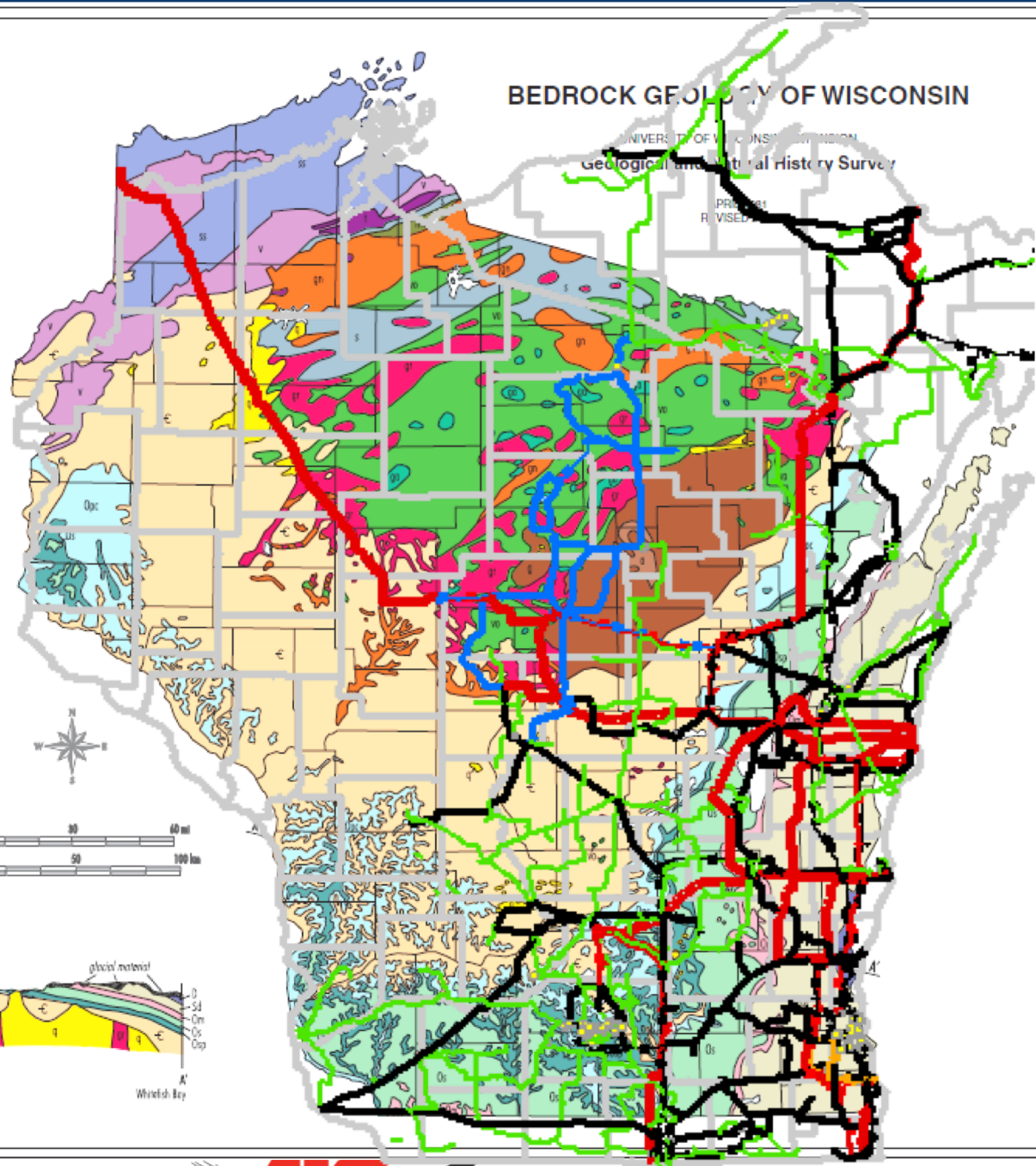

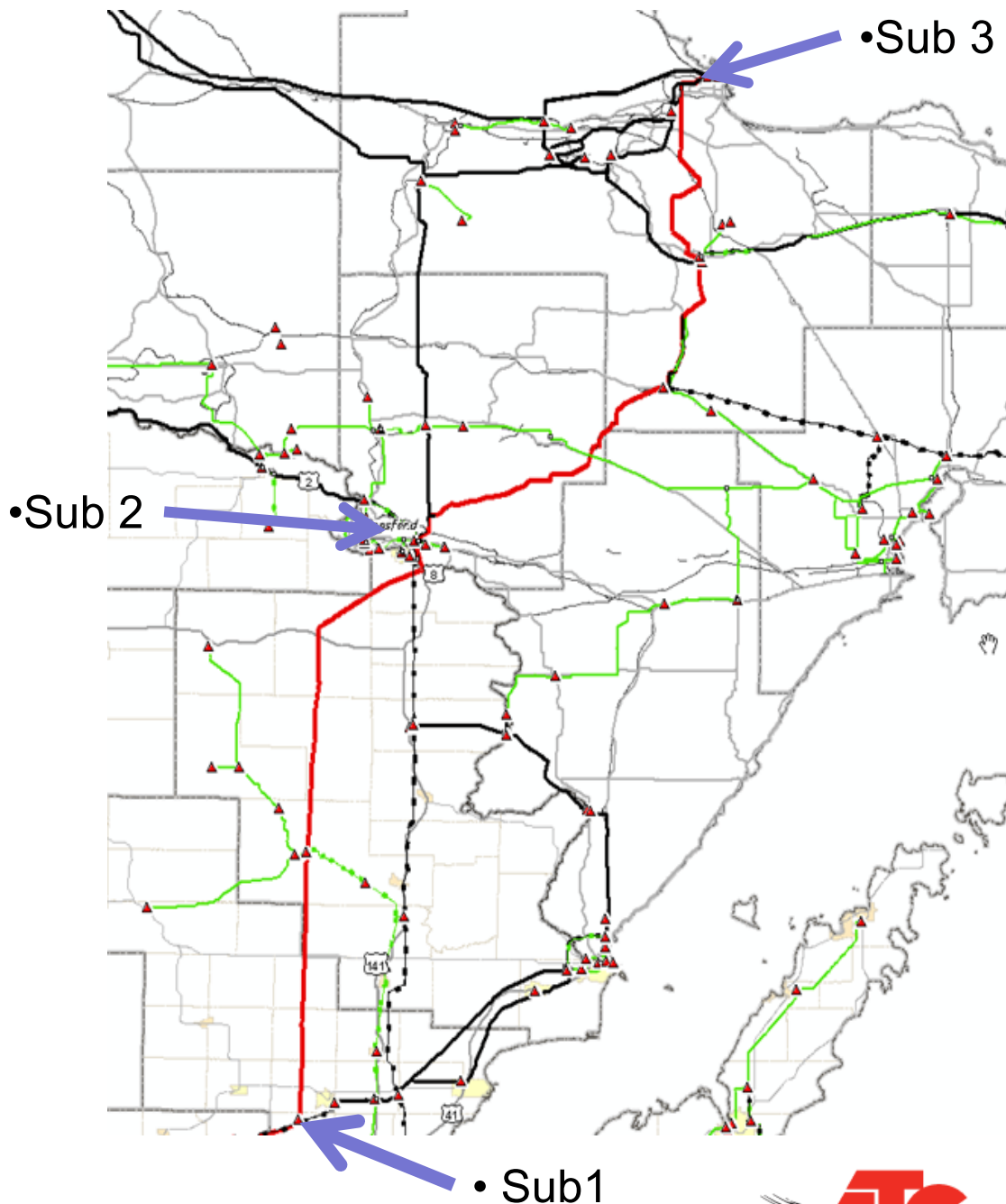

ATC's Plan Mitigate-- Choice of Location

- 345kV radial
- Approximately 160 Miles long
- Green Bay to Marquette Line

GIC Neutral Current - DC Amps [Per EPRI + Current flows from ground to the transformer]

ATC's Plan Mitigate-- Choice of Location

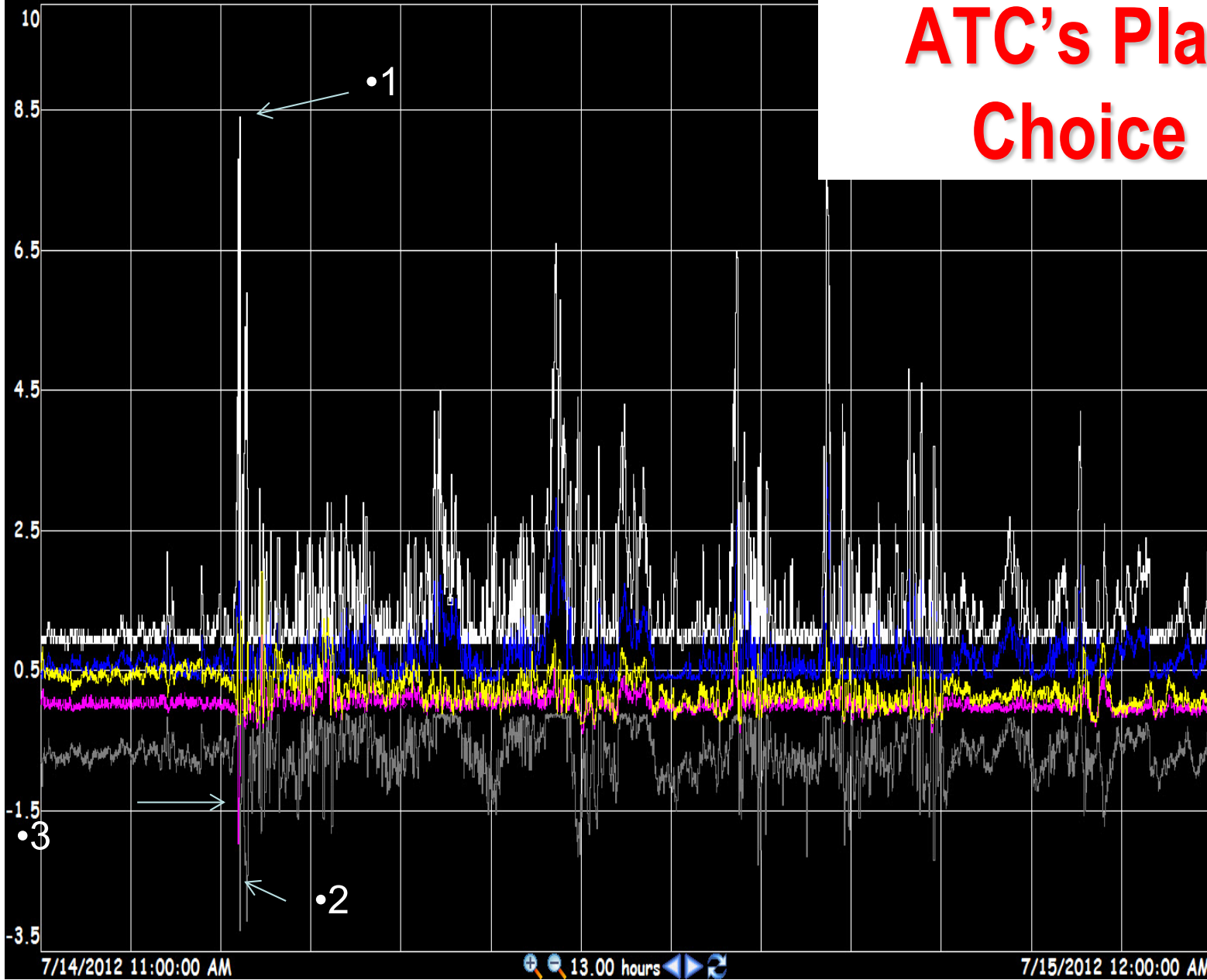

- KEW.XF.T10_NEUT_CURR_A_N.ANALOG 5.0
- MGN.XF.T11_NEUT_CURR_A_N.ANALOG 5.0
- PLA.XF.T1_NEUT_CURR_N.A_N.ANALOG 1.9
- PLA.XF.T1_NEUT_CURR_P.A_N.ANALOG -0.2
- POB.XF.T1_NEUT_CURR_A_N.ANALOG
- POB.XF.T2_NEUT_CURR_A_N.ANALOG
- NMA1.XF.T21_NEUT_CURR_A_N.ANALOG



Operational History

- Auto Operation
 - Normal mode of operation
 - Goes into blocking if GIC above 5 amps for 1 minute
 - Goes back to normal mode when GIC is below 5 amps for 60 minutes
 - No operator intervention needed
 - Device has operated approximately 33 times since its in service in 2015
 - No negative effects to the system to date

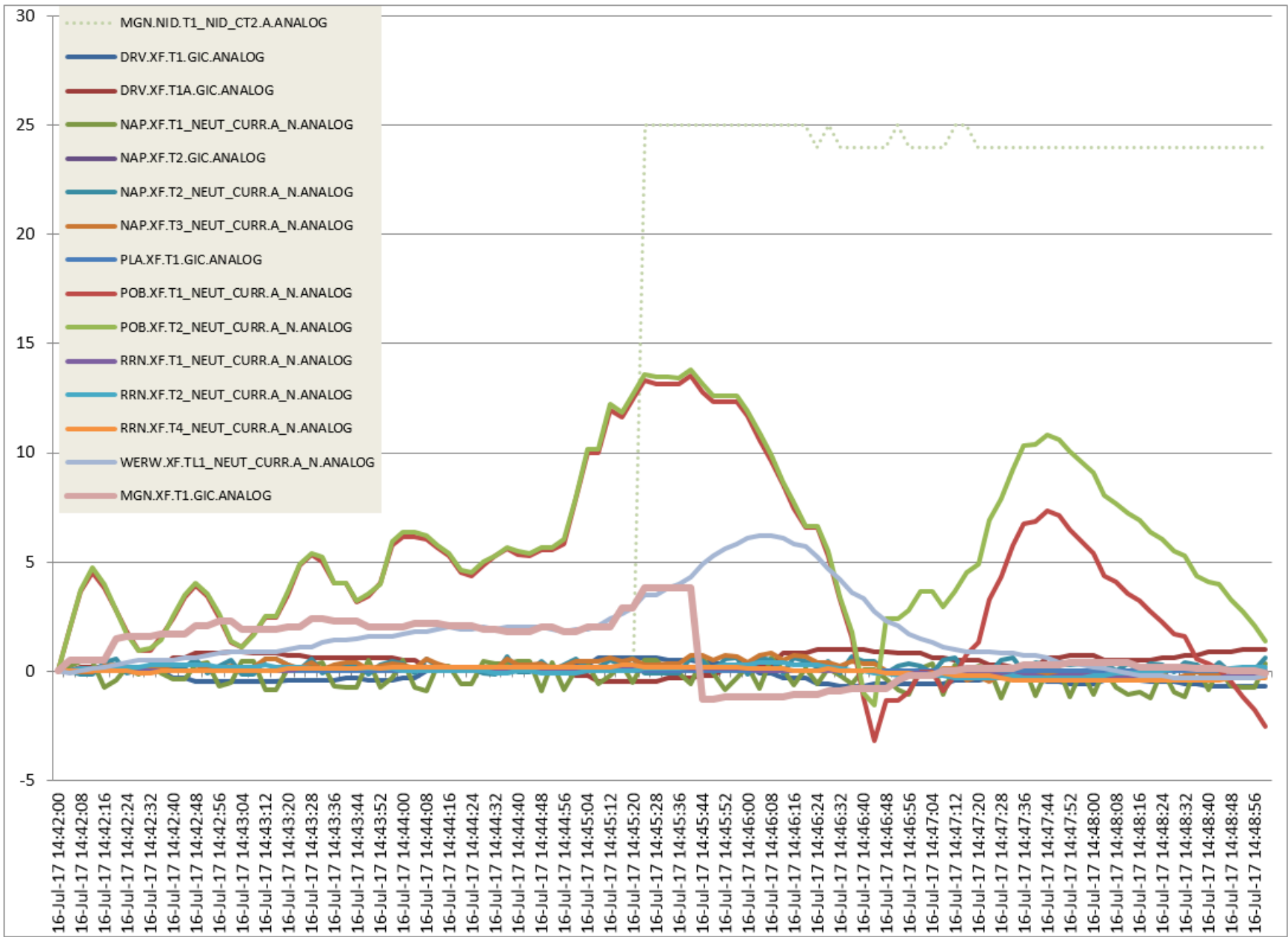

Sequence of Operation Normal Mode

Normal Mode of Operation (Red = Current Flow)

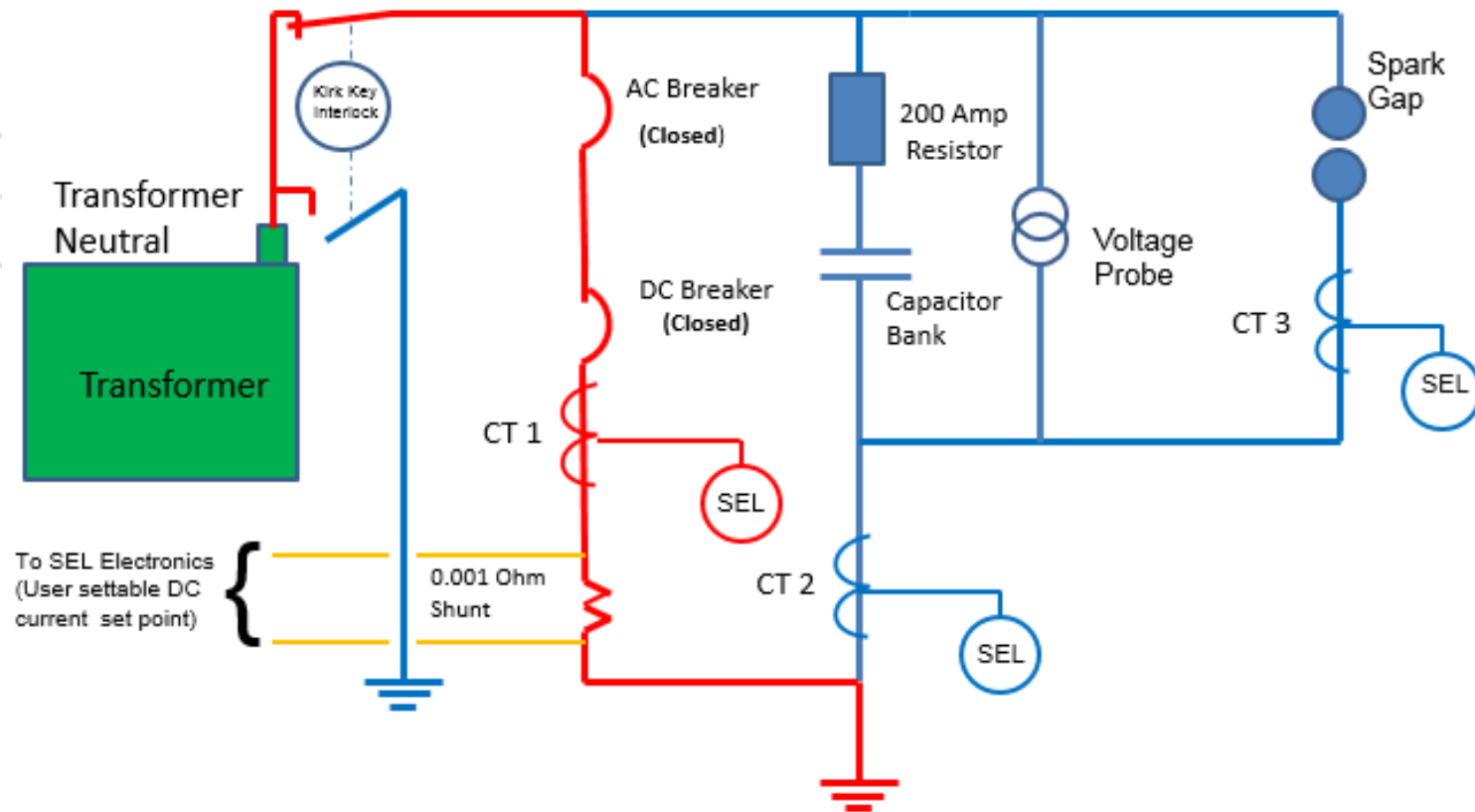

SolidGround™ One Line Diagram

Sequence of Operation Transitioning to GIC Blocking

Going into the GIC Mode (Red = Current Flow)

(GIC= Geomagnetic Induced Current)

SEL Electronics sense quasi-DC current above set point value and calls for the DC breaker to open.

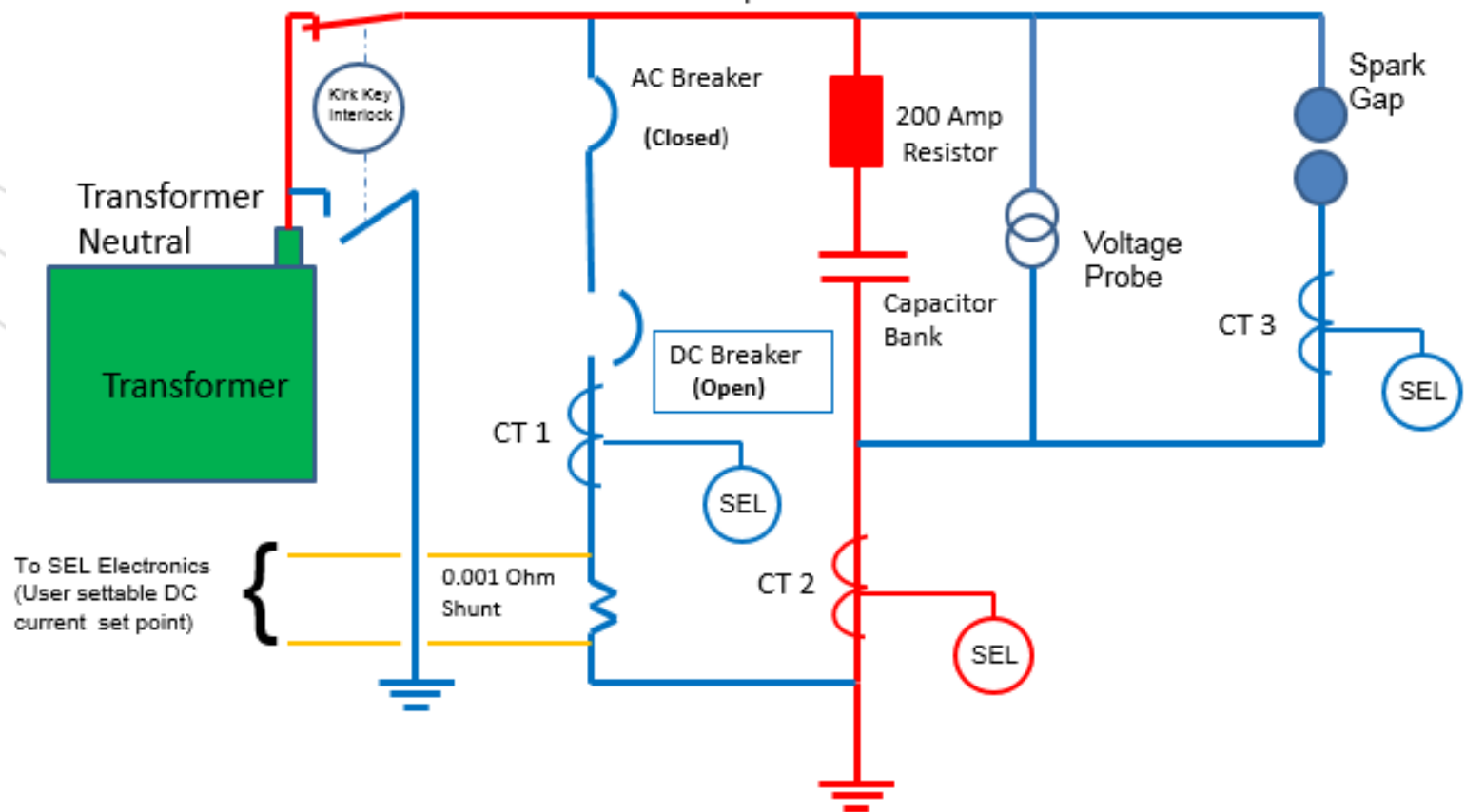

SolidGround™ One Line Diagram

Sequence of Operation Ground Fault in GIC Mode

Ground Fault in the GIC Mode (Red = Current Flow)

(GIC= Geomagnetic Induced Current)

When a ground fault occurs, spark gap protects capacitor and transformer from overvoltage. The spark gap assembly can handle many ground faults. Normal operation will cause the AC breaker to close to reset to stand-by mode (see next slide). If AC breaker fails to close a major alarm will be generated.

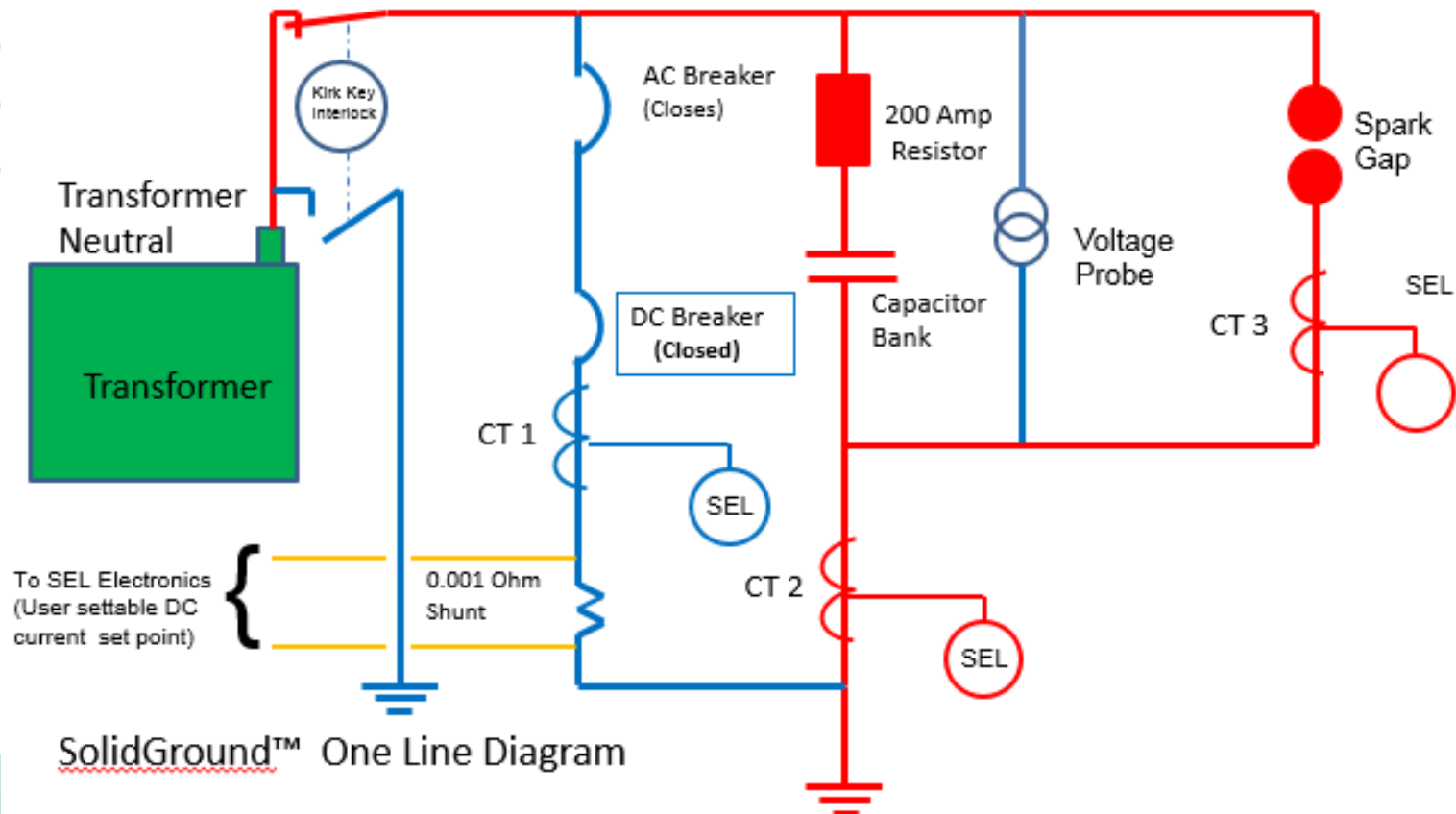

Sequence of Operation Reset to Normal Mode

Normal Mode of Operation (Red = Current Flow)

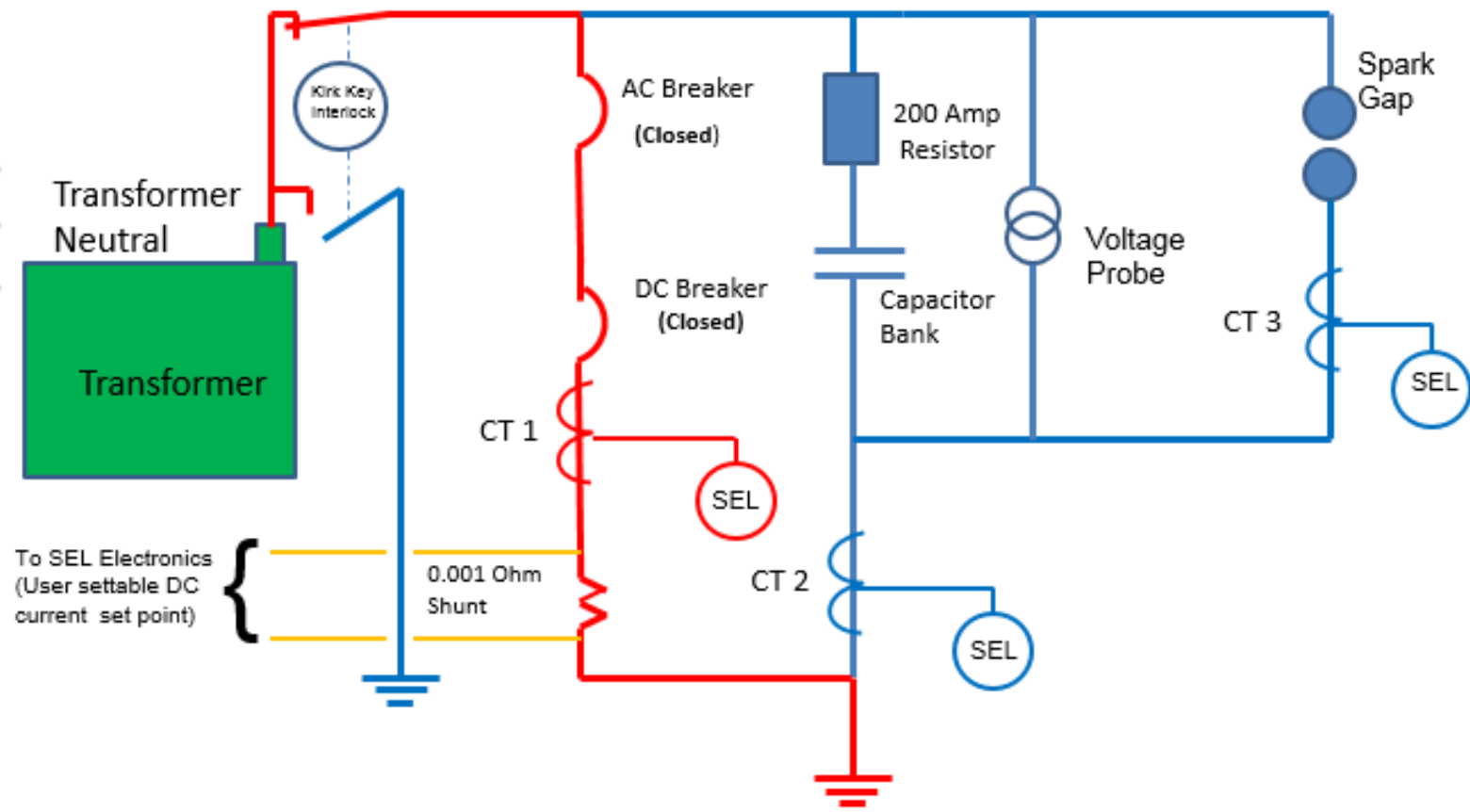

SolidGround™ One Line Diagram

MGN NID IN "BY-PASS" MODE

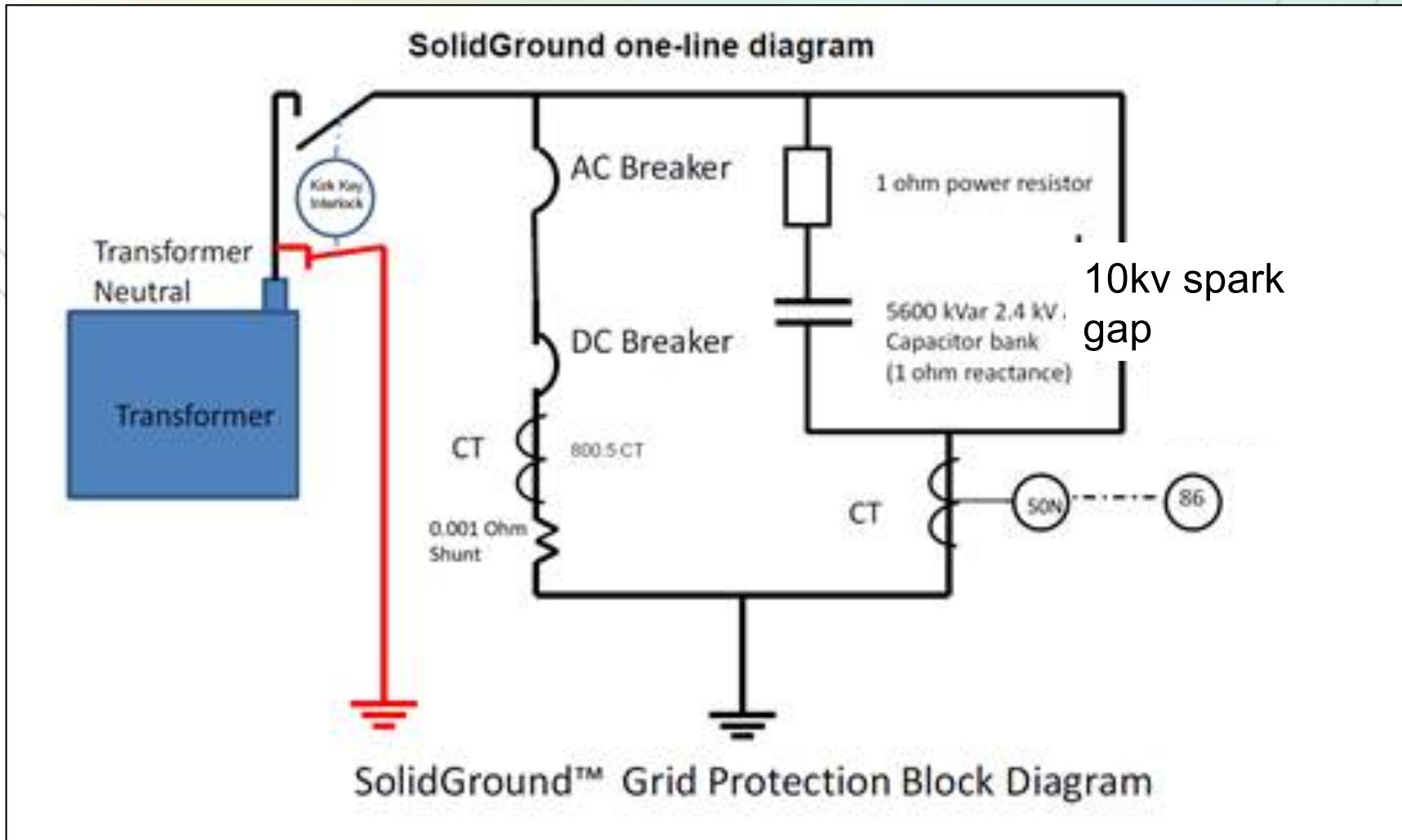

Questions?

Michael J. Londo

Consultant, Transmission Reliability Administrator,
ATC Real-Time Operations

mlondo@atcllc.com

262-506-6740

32



David Wojtczak

Manager, Asset Technology and Services, ATC

dwojtczak@atcllc.com

262-506-6823

32

